

The CVR400 is a multi-standard broadcast quality standards converter, synchronizer and timebase corrector. With 12-bit sampling and capable of handling analog component, composite and Y/C signals, the CVR400 is a powerful and versatile unit. Standards conversion between 525 (NTSC) and 625 (PAL) line standards employs a powerful 20 point, 4 field, 5 line interpolation aperture to give smooth motion and maximum vertical resolution.

The Kudos Plus CVR400 has a DC input for redundant PSU capability and is provided in a compact half rack width housing with remote control capability via Ethernet.

Kudos Plus CVR400

Composite & Component Standards Converter & Synchronizer



Features

- Standards converter
- Synchronization & timebase stabilization
- 20 point vertical-temporal aperture
- 12-bit decoding with 5-line comb filter
- 12-bit encoding
- Composite, component & YC inputs & outputs
- Inputs NTSC, N4.43, PAL, PAL-M, PAL-N SECAM with automatic input detection
- Outputs NTSC, NTSC-J, PAL, PAL-M, PAL-N
- Unique 'Floating Mode'* for no lip-sync error
- Composite inputs tolerant to noise and errors
- Video gain, black level, chroma gain, NTSC hue

- Format conversion
- USB remote control
- Compact 1/2 rack width with rack mount kit
- Optional external PSU for redundancy

Applications

- Incoming feeds
- Satellite down-link & radio links
- Ingest/PC capture pre-processing
- Duplication
- VHS dubbing

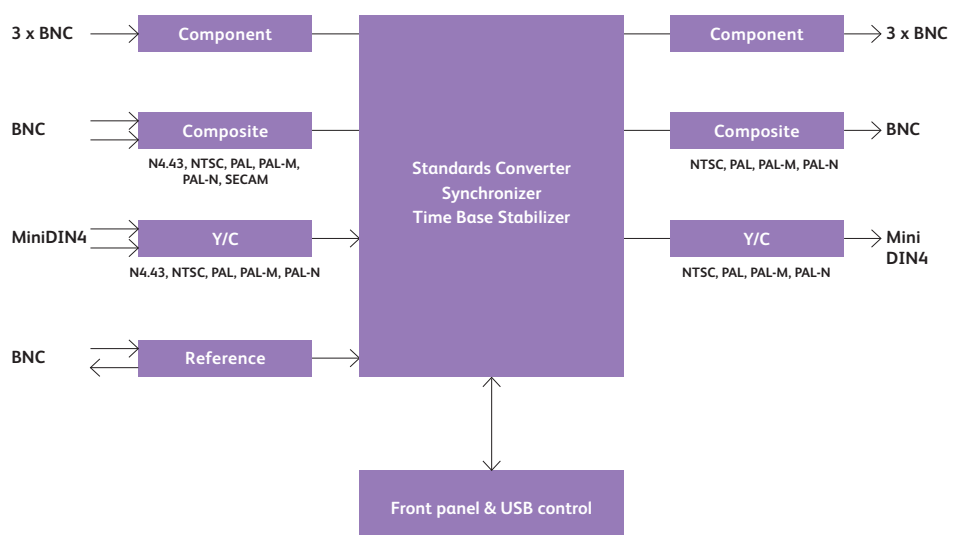

CVR400 Standards Converter

Full Product List

Base Model
Kudos Plus CVR400
(3598400)

Kudos Plus CVR400 multi-standard standards converter, synchronizer and timebase stabilizer with analog component, composite and YC interfaces, with 12-bit sampling and 10-bit processing.

Option

Rack Mount Kit
(INSY-MNT-KIT)

To mount one or two units in a 19" rack.

Redundant PSU
(INSY-PSU-EXT)

External PSU, provides redundant PSU operation.

Company policy is one of continuous product improvement. Specifications are therefore provisional and subject to change without notice. All other trademarks mentioned herein are duly acknowledged.

snellgroup.com

Technical Specification

Video Input	
2 x Composite	27 MHz, 12-bit sampling NTSC, N4.43, NTSC-J, PAL, PAL-M, PAL-N, SECAM with automatic detection
2 x YC	27 MHz, 12-bit sampling NTSC, N4.43, PAL, PAL-M, PAL-N, with automatic detection (MiniDIN4)
1 x Component	27 MHz, 12-bit sampling Input Format YPbPr (3 x BNC) Composite or Y (BNC loop-through)
Reference	
Video Output	
1 x Composite	27 MHz, 12-bit D to A. Output Formats NTSC, NTSC-J, PAL, PAL-M, PAL-N**
1 x YC	27 MHz, 12-bit D to A. Output Formats NTSC, NTSC-J, PAL, PAL-M, PAL-N (BNC or MiniDIN4)**
1 x Component	27 MHz, 12-bit D to A Standards 525; 625/YPbPr; RGB USB
Remote control	
Control Features	
Input select	Composite A, B; YC Component YPbPr
Input standards	NTSC NTSC, NTSC-J
Composite output	NTSC, NTSC-J, PAL, PAL-M, PAL-N
Frame freeze	Freezes next frame (sync mode)
Field freeze	Freezes next field (sync mode)
Luminance gain	Preset; ±6 dB
Chrominance gain	Preset; ±6 dB
Black level	Preset; ±100 mV
NTSC hue	Preset; ±30 °
Genlock phase	Preset; ±1 line
Genlock mode	Lock to reference; Lock to input (stabilized); if same line standard; Free-run
Output pattern	Black; Color Bars
Default output	When input is lost: go to black; go to color bars
Decoder/Encoder	ARC, ACC, comb, pedestal, DNR, CTI

Indication/Monitoring (also Logging/RollTrack)	
Input standard Reference	Present; Standard Present; Error (Error indicated if the reference is not the same line standard as the input)
Power	Standby

System Parameters	
Processing	≥10 bit
Conversion aperture	4 field / 5 line
Vertical interval	All luminance data passed when input & output are the same standard
Reference lock range	Greater than ±80 ppm

Signal Delays	
Input lock mode	CVBS 525 to 525, 625 to 625 200 µs
Float mode	CVBS 525 to 525, 625 to 625 950 µs
Any input	625 to 525 (independent of Genlock) 70 ms
Any input	525 to 625 (independent of Genlock) 70 ms

Power	
Input voltage range (Primary)	100-240 VAC, 47-63Hz 0.4a via three pin IEC power socket
Input voltage range (Secondary)	12 DC @ 1.5A via 2.1mm ring lock jack

Mechanical	
Dimensions	½ 1RU rack (44x220x250mm)
Temperature	0°C to 35 °C operating -20 °C to +70 °C storage

*Floating Mode

Without a reference the output will either free-run or lock to a stabilized input sync if operating in synchronize mode. In this stabilized or 'floating mode' the output will always follow shortly after the input, so preventing lip-sync errors and frame drop/repeat. The inputs are highly tolerant to unstable and noisy sources, while the synchronizer always creates correctly aligned images, even during sync disturbances and asynchronous input switches.

** No SCH lock



KP15 v3